

**Model:**

FLC12-8, FLC12-13,

FLC24-8, FLC24-13

Page 1 of 1

# Fluorescent Interior Light

Operating Instructions  
Please read these instructions before use



The FLC series of Fluorescent Light assemblies have been designed for internal use, i.e. not exposed to outside elements.

1. Remove the four (4) Phillips head screws from the both ends of the unit (retain for re-fitment later), remove diffuser, then carefully remove end plate with on / off switch ensuring not to damage wiring.
2. With wide (8mm) flat blade screwdriver carefully pry the base assembly away from main assembly, ensuring not to damage the figure 8, power cable.
3. Place the base assembly in the location it is to be secured.
4. Mark and drill the appropriate hole size for securing base assembly, as well as 3- 4mm hole for power cable.
5. Feed power cable through panel hole and secure base.
6. Refit main assembly ensuring not to pinch any cables.
7. Connect the twin figure 8 power cable to DC power source i.e. 12/24V positive to plain RED wire and 12/24V negative to RED / BLACK wire.
8. Re-fit end plate with rocker switch back in position with four (4) self-tapping screws previously removed.
9. Test unit by switching rocker switch "on" and tube should illuminate.
10. Re-fit diffuser into position and then blank end plate with four (4) self-tapping screws previously removed.
11. Test unit again to ensure operation.

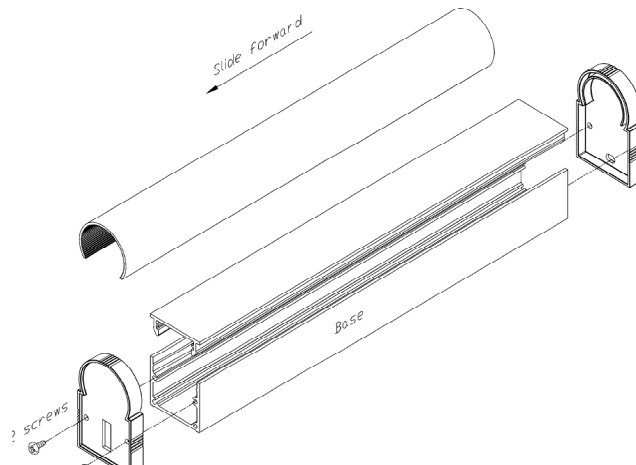

**Warranty Conditions:** The product is warranted to be free from defects in materials and workmanship under normal use and service for a period of 24 months from the date of sale. This warranty covers defective parts and workmanship provided that the product is shipped prepaid to the seller within 24 months of purchase of goods. This warranty is limited to the repair or replacement (at the manufacturers' discretion) of parts and shipping prepaid to the original despatch destination. We regret that no liability can be accepted for consequential or special damages of any kind howsoever arising in connection with products supplied by the seller. This warranty is in lieu of all other warranties expressed or implied. No representative is authorised to assume for the seller any other liability in connection with the seller's products.