

Model:

FL12-20, FL24-20, FL24-20LP

FL12-40, FL24-40

Page 1 of 1

**Low Voltage
DC Fluoro Inverters
Suits T8 Tubes**

Operating Instructions

Please read these instructions before use



1. Disconnect the battery supply before contact with any component of the Inverter
2. Ensure that the wire used for connecting the inverter has an insulation rating of minimum 240 volt
3. When wiring, use an in-line fuse holder with a fuse (5A for 12V and 2A for 24V) and place in the positive line
4. Ensure that the two (2) filaments (one either end) on the tube are connected to the module connectors as marked (i.e. F1 and F2)
5. Check that polarity is not reversed (positive to negative etc) and that correct input voltage is applied
6. Mount in a well ventilated area
7. Locate the inverter as close as possible to fluoro tube

Note: We recommend the use of fibre washers with locating screws (if screws are being used) when securing module. If metal washers are used, ensure they (or any other metal surface e.g. screwdriver) DO NOT touch transistors.

If transistors are shorted, damage to the module may result which void warranty.

FL12-20	Suits 15W-20W T8 Tubes
FL24-20	Suits 15W-20W T8 Tubes
FL24-20LP	Suits 15W-20W T8 Tubes
FL12-40	Suits 36W-40W T8 Tubes
FL24-40	Suits 36W-40W T8 Tubes

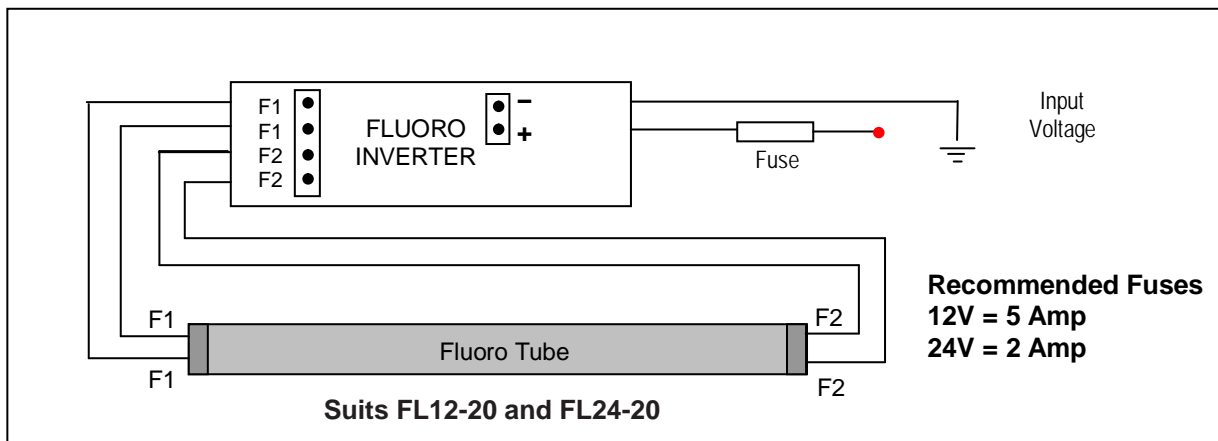
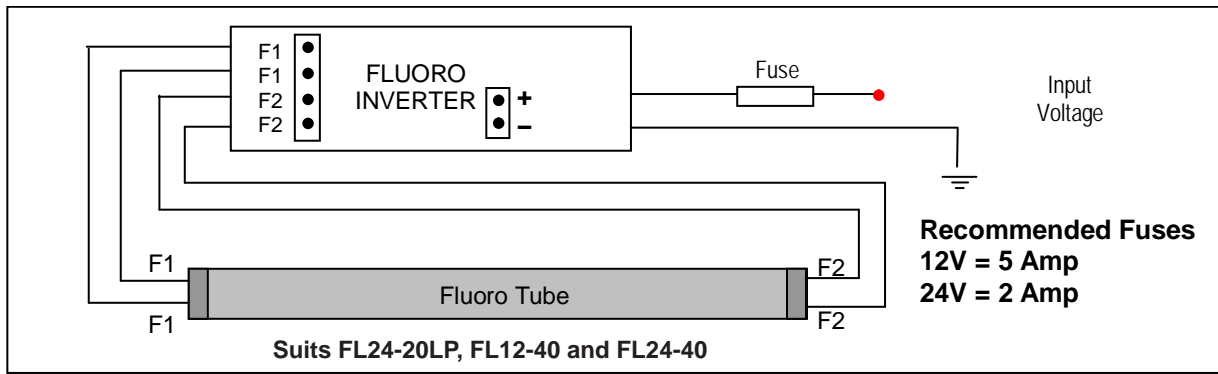

Warning: Do not remove or replace tube or fuse while power is supplied to the inverter.
Ensure tube is correctly seated.

Warranty Conditions: The product is warranted to be free from defects in materials and workmanship under normal use and service for a period of 24 months from the date of sale. This warranty covers defective parts and workmanship provided that the product is shipped prepaid to the seller within 24 months of purchase of goods. This warranty is limited to the repair or replacement (at the manufacturers' discretion) of parts and shipping prepaid to the original despatch destination. We regret that no liability can be accepted for consequential or special damages of any kind howsoever arising in connection with products supplied by the seller. This warranty is in lieu of all other warranties expressed or implied. No representative is authorised to assume for the seller any other liability in connection with the seller's products.