



Warning: Before commencing work ensure that the negative terminals from the main and auxiliary batteries have been disconnected.

Wiring Instructions

1. Mount the isolator high up in the engine bay away from moisture and any source of external heat and inflammable sources. e.g **Fuel Lines, Exhaust systems.**
2. Scratch away the paint from the body surface and earth the black wire onto the body.
3. Connect the main battery terminal of the solenoid to the positive terminal of the main battery using 6B&S cable.
4. Connect the auxiliary battery terminal of the solenoid to the positive terminal of the auxiliary battery using 6B&S cable.
5. Ensure that the auxiliary battery is correctly earthed using a minimum 3B&S cable.
6. **(Optional)** Connect the **blue wire** to Auxillary Battery Positive via a momentary switch for manual override. If you do not use this option, ensure that it is secured away from ground or + voltage.
7. **(Optional)** Connect the **green wire** to positive of supplied LED.

Specifications	
Max Current	100 A
Cut In Volt	26.4 V
Cut Out Volt	25.4 V

L.E.D Codes :-

ON: Solenoid contacts closed, normal operation.

OFF: Solenoid contacts open, normal operation.

Flashing : Abnormal Operating conditions. These are as follows: Low Main Battery (**Below 21V**), High Main Battery (**Above 30.2V**), Solenoid Coil Shorted (Latched alarm requires disconnection of solenoid to clear), Excessive Solenoid Drop (Latched alarm/requires disconnection to reset)

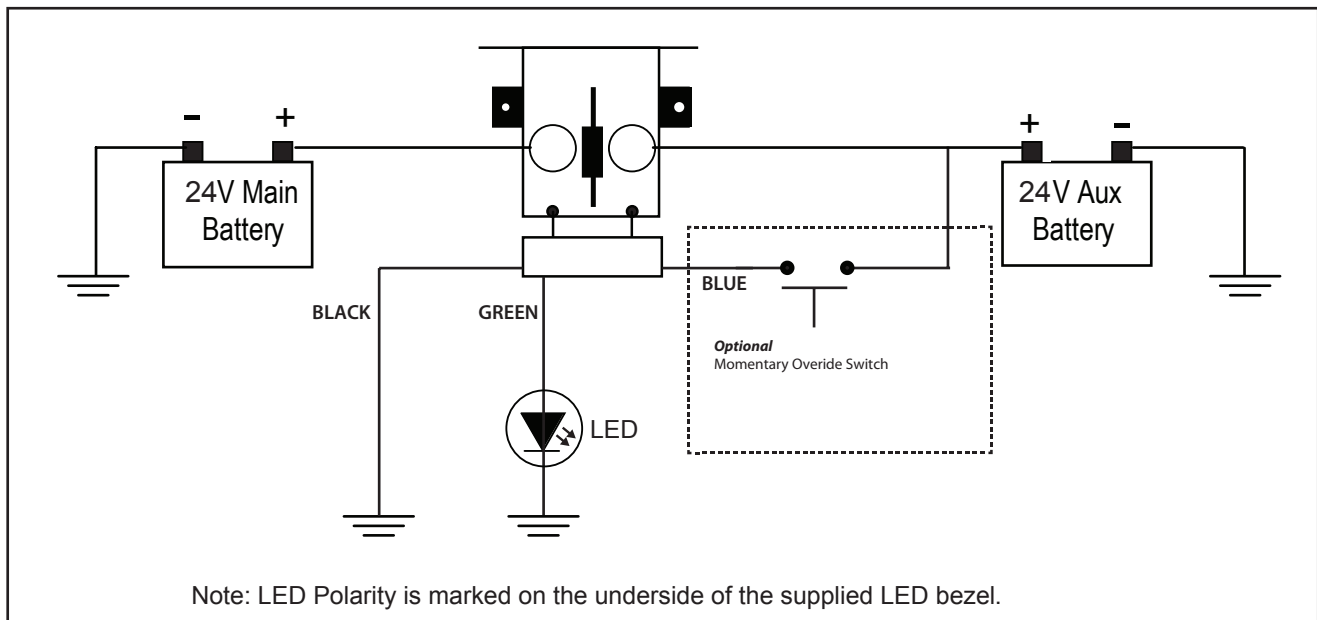

Warranty Conditions: The product is warranted to be free from defects in materials and workmanship under normal use and service for a period of 24 months from the date of sale. This warranty covers defective parts and workmanship provided that the product is shipped prepaid to the seller within 24 months of purchase of goods. This warranty is limited to the repair or replacement (at the manufacturers' discretion) of parts and shipping prepaid to the original despatch destination. We regret that no liability can be accepted for consequential or special damages of any kind howsoever arising in connection with products supplied by the seller. This warranty is in lieu of all other warranties expressed or implied. No representative is authorised to assume for the seller any other liability in connection with the seller's products.