

The unit is designed to protect the main vehicle battery from over discharge, by disconnecting the auxiliary accessories when the main battery voltage drops below 11.0 Volts. The accessories remain disconnected until such time as the battery voltage reaches normal charging voltage. The unit is designed to carry auxiliary loads of up to 8 Amps.

### Installation

1. Disconnect the earth terminal from the battery.
2. Mount the unit with wiring facing downwards away from moisture and any source of external heat (e.g. exhaust systems).
3. Connect the Blue lead of the unit to the vehicle ignition circuit (positive).
4. Connect the Red lead of the unit to auxiliary equipment.
5. Connect the White lead of the unit to the auxiliary equipment earth (negative).
6. Connect the Black lead of the unit to the vehicle earth (negative).
7. Reconnect the earth terminal to the main vehicle battery and test unit.
8. Ensure 10A fuse is installed in the Blue wire

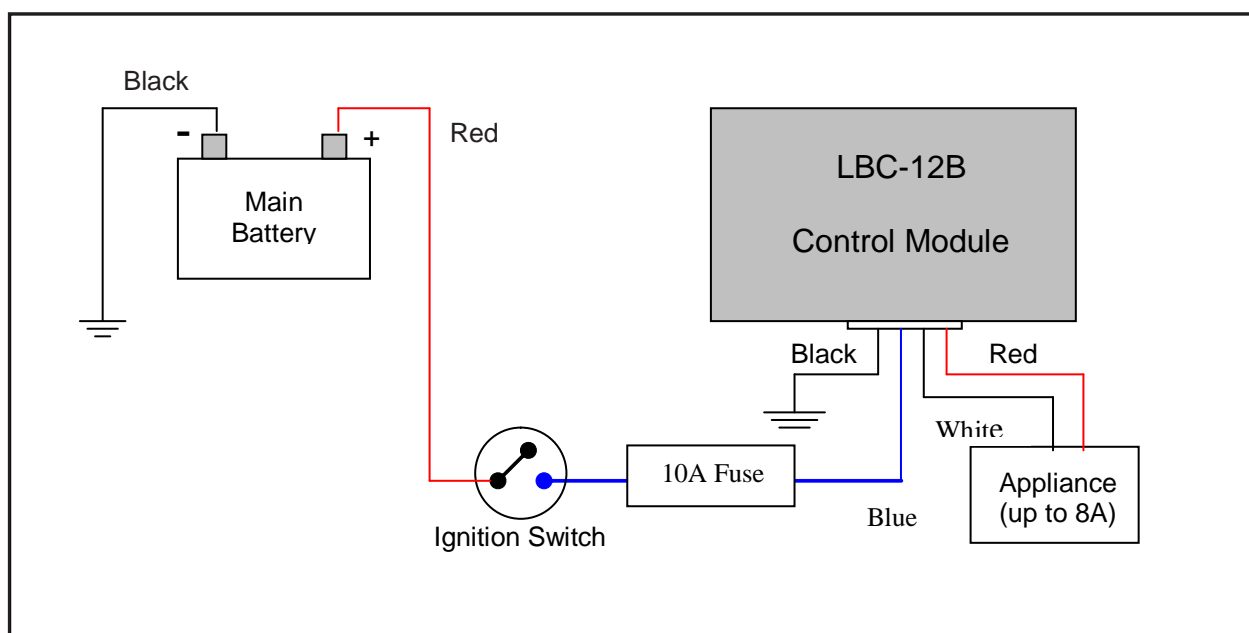

**Warning: 10A Fuse Must Be Installed.**

*Warranty Conditions:* The product is warranted to be free from defects in materials and workmanship under normal use and service for a period of 24 months from the date of sale. This warranty covers defective parts and workmanship provided that the product is shipped prepaid to the seller within 24 months of purchase of goods. This warranty is limited to the repair or replacement (at the manufacturers' discretion) of parts and shipping prepaid to the original despatch destination. We regret that no liability can be accepted for consequential or special damages of any kind howsoever arising in connection with products supplied by the seller. This warranty is in lieu of all other warranties expressed or implied. No representative is authorised to assume for the seller any other liability in connection with the seller's products.