



Congratulations on purchasing your new GSL Electronics Microprocessor Controlled Battery Equalizer. The equalizer is designed for use in 24V battery systems where a centre tap is used to supply heavy 12V loads. This innovative microcontroller based design ensures that both 12V series connected batteries remain balanced during charging even under highly unbalanced load currents, ensuring the highest possible battery life expectancy and reliability.

Installation & Safety Precautions:

1. The following connection sequence is to be followed: Ground (BLACK), Input (BLUE), Output (RED) and Control (WHITE).
2. Preferably mount the unit inside the vehicle. Avoid locations where external heat is produced e.g. exhaust system or where the batteries are located.
3. Choose a position with good ventilation where air can pass freely around the unit.
4. Ensure the unit is protected from water spray and other sources of contamination e.g. oil, grease and dust.
5. Ensure that unit is installed away from any flammable fumes, liquids or materials.
6. During equalization process, do not use a naked flame near a battery, due to gases emitted from the battery, which may ignite and explode.
7. Never smoke or light cigarettes near a battery.
8. Do not place tools on top of battery or allow tools to fall on battery.
9. Always wear eye protection near a charging battery.
10. Ensure a "well" ventilated area is used when testing or re-charging batteries.
11. Ensure ventilation is adequate and venting holes are not obstructed. Inadequate ventilation may over-heat the unit and cause inefficient operation.
12. If skin or clothing comes into contact with acid, flush the area(s) with water immediately. Seek medical attention if necessary.

Should product require service, return it to your place of purchase for Warranty Advice.

If the unit is in the following conditions. reset as follows:-

Output Over Voltage : If the output over voltage protection has been tripped then there will be no operation from the unit. Contact supplier or GSL Electronics for Warranty Advice.

Thermal Protection : For your safety and for the longevity of your purchase, the unit will shut down to protect itself and your batteries when the unit exceeds its nominal operating temperature. To reset this condition the unit must be disconnected from the battery for at least one minute to allow cooling and for the microprocessor to reset.

Were the unit does not reset, contact your Supplier or GSL Electronics for Warranty Advice.

LED Indicators:

Your new equalizer is fitted with a microprocessor which evaluates the state of the Equalizer and displays the operating mode of the unit via two LED indicators.

Input LED: Nominal input range, above 25V, is indicated by the Input LED remaining solid. Flashing Input LED indicates that input is below 25V. If the input voltage drops below 22V the Equalizer will switch off. When the voltage returns to above 23V the unit will return to normal operation.

Output LED: This LED indicates the power output of the Equalizer

When the LED is flashing this indicates that the Equalizer either:-

A) Current output less than 1amp. This would indicate that the battery is equalized

B) or the unit has just entered current limit. A solid output LED indicates that the unit is operating with in the nominal range.

The LED will remain off when either:-

A) The Ignition Wire is disconnected.

B) Outp ut Over Voltage or Thermal Protection

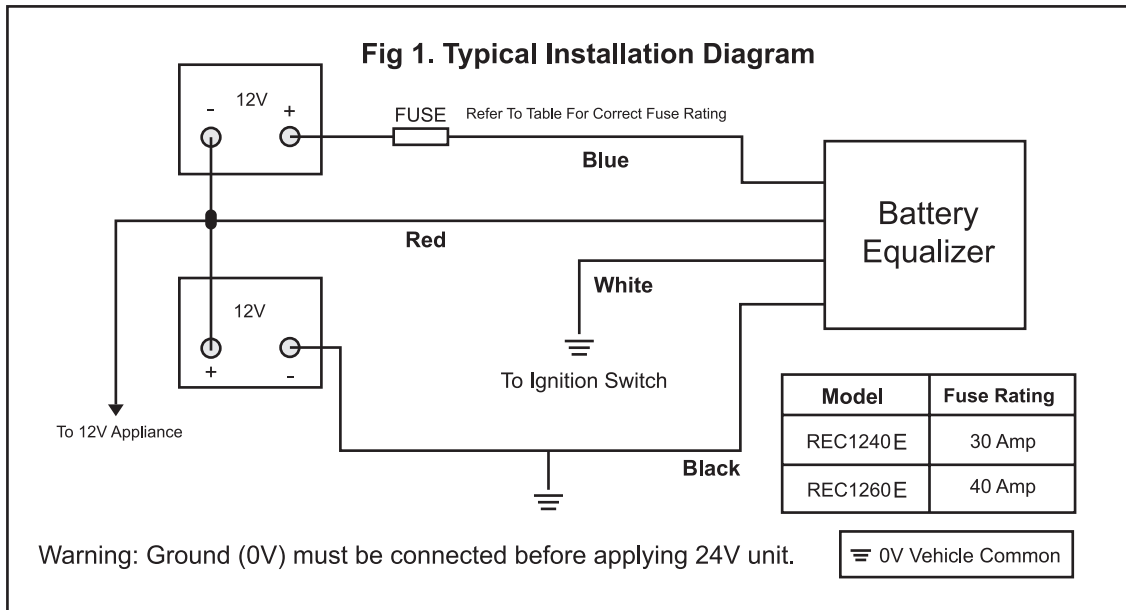

Specifications	REC-1240E	REC-1260E
Input Voltage	23VDC to 30VDC	23VDC To 30VDC
Output Voltage	½ Input Voltage ± 3%	½ Input Voltage ± 3%
Typical Efficiency	Greater Than 85%	Greater Than 85%
Max Output Current	40mA	60mA
Stand - By Current	20mA	20mA
Features	Short Circuit Protection Reverse Input Protection Over Voltage and Thermal Protection	
Dimennsions mm [L x W x H]	285x175x65	285x175x65
Weight	2.5Kg	2.6Kg

Warranty Conditions: The product is warranted to be free from defects in materials and workmanship under normal use and service for a period of 24 months from the date of sale. This warranty covers defective parts and workmanship provided that the product is shipped prepaid to the seller within 24 months of purchase of goods. This warranty is limited to the repair or replacement (at the manufacturers' discretion) of parts and shipping prepaid to the original despatch destination. We regret that no liability can be accepted for consequential or special damages of any kind howsoever arising in connection with products supplied by the seller. This warranty is in lieu of all other warranties expressed or implied. No representative is authorised to assume for the seller any other liability in connection with the seller's products.