

Warning: Before commencing work ensure that the negative terminals from the main and auxiliary battery have been removed. Do not short any wiring to body work except the black earth wire.

Wiring Instructions

1. Mount the isolator high up in the engine bay away from moisture, fuel lines and any source of external heat e.g. exhaust systems.
2. Scratch away the paint from the body surface and earth the black wire onto the body.
3. Connect the main battery terminal (to the bolt of isolator with the red wire connected), using 6B&S cable, to the positive terminal of the main battery.
4. Connect the auxiliary battery terminal to the other bolt, using 6B&S cable, to the positive terminal of the auxiliary battery.
5. Ensure that the second battery is correctly earthed using a minimum 3B&S cable.
6. (Optional) Connect the blue wire to earth via a momentary switch for manual override. If you do not use this option, ensure that it is secured away from ground or + voltage.

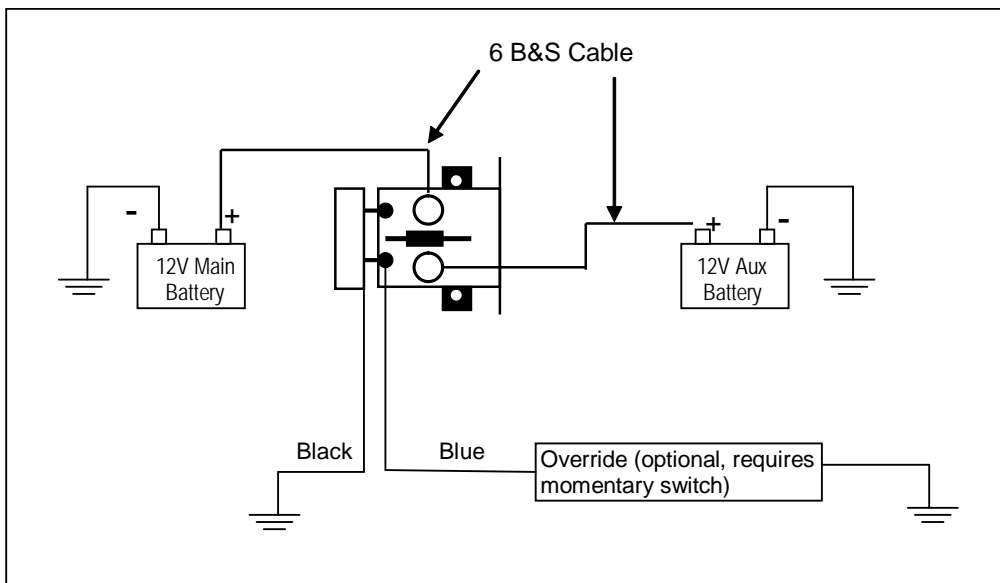

Charging Sequence

CONNECTS

Aux. battery for charge when main is at 13.5V.

DISCONNECTS

Aux battery when main is at 12.5V.

Note: Solenoid will not operate if there is not a voltage present on both the AUX and MAIN terminals. Unless the override cable is connected.

Warranty Conditions: The product is warranted to be free from defects in materials and workmanship under normal use and service for a period of 24 months from the date of sale. This warranty covers defective parts and workmanship provided that the product is shipped prepaid to the seller within 24 months of purchase of goods. This warranty is limited to the repair or replacement (at the manufacturers' discretion) of parts and shipping prepaid to the original despatch destination. We regret that no liability can be accepted for consequential or special damages of any kind howsoever arising in connection with products supplied by the seller. This warranty is in lieu of all other warranties expressed or implied. No representative is authorised to assume for the seller any other liability in connection with the seller's products.