

**When Installing Please Note:**

1. The following connection sequence is to be followed: Ground , Input , Output .
2. Preferably mount the unit inside the vehicle. Avoid locations where external heat is produced e.g. exhaust system or where the batteries are located.
3. Choose a position with good ventilation where air can pass freely around the unit.
4. Ensure the unit is protected from water spray and other sources of contamination e.g. oil, grease and dust.
5. Ensure that unit is installed away from any flammable fumes, liquids or materials.

**Note:** A spark can sometimes be generated during the Input connection, due to the current required to charge the capacitors in the reducer.

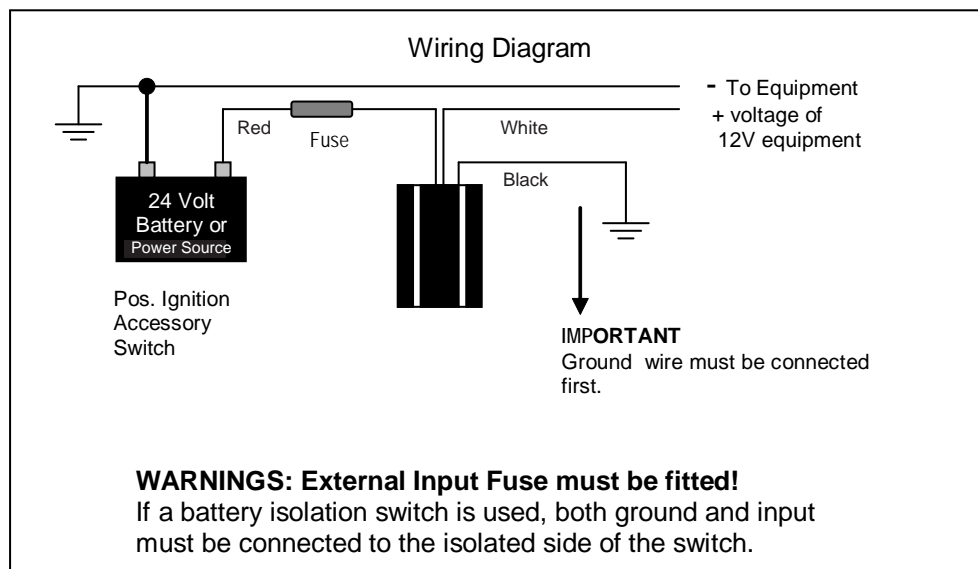

Part No.	Fuse
SM-107	10 amp

The reducer is protected against over voltage, under voltage (during cranking of vehicle), over current (overload) and voltage spikes or surges. Under any of the above conditions the converter will shut down.

**Notes:** To reset the reducer, disconnect Input and wait 20 sec. before reconnecting

\* If the unit continues to shut down after being reset and the connections and input voltage have been checked then please return the unit for repair.

*Warranty Conditions:* The product is warranted to be free from defects in materials and workmanship under normal use and service for a period of 24 months from the date of sale. This warranty covers defective parts and workmanship provided that the product is shipped prepaid to the seller within 24 months of purchase of goods. This warranty is limited to the repair or replacement (at the manufacturers' discretion) of parts and shipping prepaid to the original despatch destination. We regret that no liability can be accepted for consequential or special damages of any kind howsoever arising in connection with products supplied by the seller. This warranty is in lieu of all other warranties expressed or implied. No representative is authorised to assume for the seller any other liability in connection with the seller's products.