

STFM-24 Diagram:

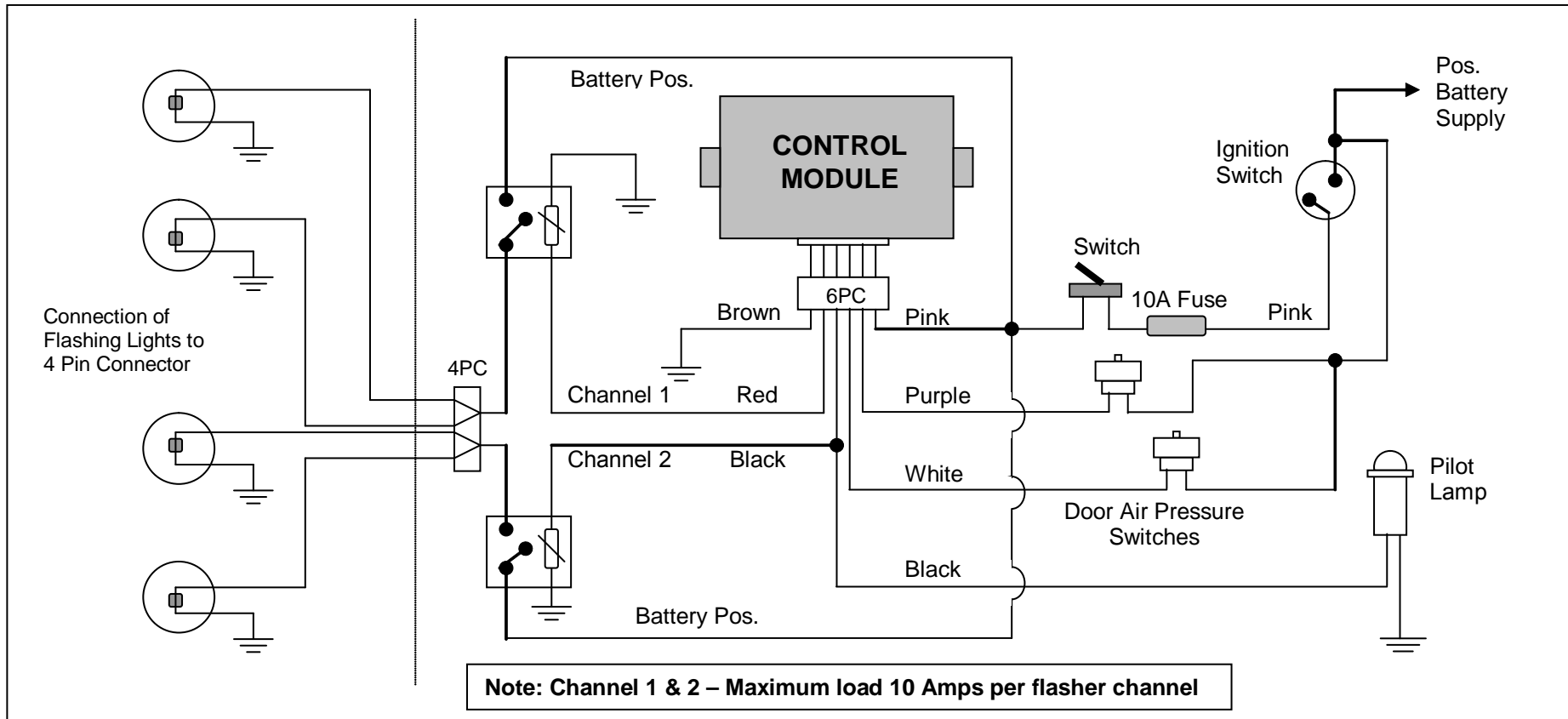

Operation of Control Module

A self-test cycle is activated whenever power is connected to the Control Module. When the door is in the open position (providing air is available) the Control Module will activate the flashing lamps and continue to do so for approximately 22 seconds after the door is closed.