

**12 Volt 10 Amp Switchmode
Uninterruptable Power Supply**
Operating Instructions
Please read these instructions before use



The unit is for bench mounted operation providing approx. 13.65VDC at 10Amps. An output mating connector kit is provided with each unit. The unit has been designed specifically for telecommunications applications demanding high reliability under heavy usage with low noise, fully automatic and unattended operation.

Applications:

Power Supply Mode: It may be used to power equipment that normally runs on a 12 Volt battery e.g. mobile communication equipment. The unit will run loads requiring up to 10 Amp output. It is fully protected against overload and short circuit and also incorporates overvoltage shut down facility.

Battery Charger Mode: As a lead acid battery charger it will provide a safe method of restoring discharged batteries. When batteries are heavily discharged the unit can provide 10 Amps continuous charging current. Fully charged batteries can be left connected to the unit indefinitely with no adverse effect on the lifetime of the batteries. An internal self resettable fuse is incorporated in the battery output. Faulty and heavily discharged batteries will not damage the power supply.

UPS Mode: The full features of the unit are utilised when both battery and load are connected so that it operates as a power supply with power fail protection. Under normal conditions an internal switch connects the battery in parallel with the load. The average load must be less than 10 Amps to ensure there is a remainder (current) available to float charge the battery.

When mains failure occurs the unit no longer provides power. The battery remains switched in parallel with the load and supports it without interruption. Restoration of the mains restarts the unit which will resume supporting the load and charging the battery again without interruption.

During extended mains failure the unit disconnects the battery before it becomes excessively discharged. The battery is automatically reconnected when mains power is restored enabling a quick charge to a workable voltage. This feature contributes to long battery lifetime and allows unattended operation of a system with minimum service calls. The battery is always being charged while mains are present. A heavily discharged battery will pull the unit into current limit and therefore reduce the voltage supplied at load terminals. For batteries in good condition that have been protected from deep discharge voltage should never be less than 10 Volts.

Installation & Safety Precautions:

1. This appliance is not meant for use by young children or infirm persons without supervision.
2. Young children should be supervised to ensure that they do not play with the appliance.
3. During charging process, do not use a naked flame near a battery, due to gases emitted from the battery, which may ignite and explode.
4. Never smoke or light cigarettes near a battery.
5. Do not place tools on top of battery or allow tools to fall on battery.
6. Always wear eye protection near a charging battery.
7. Ensure a "well" ventilated area is used when testing or re-charging batteries.
8. Ensure ventilation is adequate and venting holes are not obstructed. Inadequate ventilation may over-heat the unit and cause inefficient operation.
9. The UPS is intended for indoor use only. Do not expose it to extreme weather conditions e.g. rain or dampness.
10. If skin or clothing comes into contact with acid, flush the area(s) with water immediately. Seek medical attention if necessary.
11. Use only 12V lead acid batteries never attempt to use non rechargeable batteries.
12. The UPS contains hazardous voltages. There are no user serviceable components inside. If the AC supply cord is damaged, in order to avoid a hazard it must be replaced by the manufacturer or its service agent or a similarly qualified person.

Should product require service, return it to place of purchase.

12 Volt 10 Amp Switchmode Uninterruptible Power Supply

Operating Instructions
Please read these instructions before use



Indicator Showing UPS Status

When the unit is operating under mains power, the indicator will illuminate GREEN when operating under battery back-up, it will illuminate RED.

Battery Charging Times

The question of "how long will my battery take to re-charge" is always asked. Firstly, the charge rate (CR) of a battery is rated in Amps and the battery capacity (C) in Amp Hours. The battery manufacturer for each battery type normally states this CR. As a rule of thumb, a lead acid battery generally should be charged under 1/5 of C. For example if you have a 50Ah battery, the recommended max. charging current is: $50 / 5 = 10A$. The majority of the battery capacity would normally be charged in 5 hours with the UPS12-10 provided a negligible load. Similarly it would take approximately 10 hours to charge the same battery with an average 5A load connected. The figures above represent a worst-case scenario since the battery would generally have some remaining charge after a typical outage.

**Please note the figures quoted above could vary depending on the battery condition.*

Figure 1: Electrical Configurations

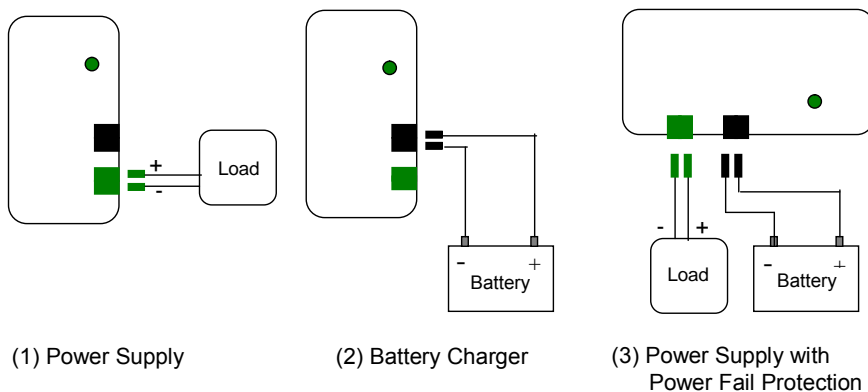
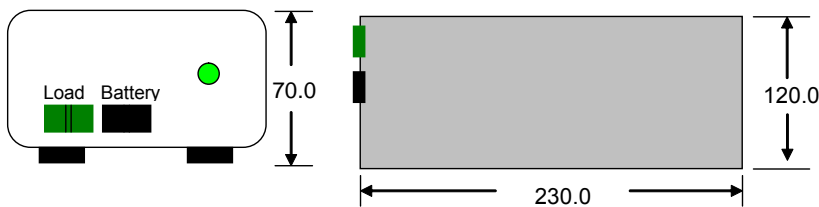

Figure 2: Dimensions (mm)



Specifications	
AC Input Voltage	180 - 250V
AC Frequency	50 Hz
AC Current (A)	1.3A max
Float Charging Voltage	13.8V @ No Load
Output Current (A) approx. max.	10A @ 13V >Vo > 6V
Battery low voltage disconnect protection	9.7V to 10V
Load regulation	< 0.3V @ 9A > Io > 1A
Line regulation	< 0.1V @ 250vac > Vin > 180vac
Output noise	< 0.1Vrms @ 60MHz BW on 1uF
Switching Frequency KHz	60KHz (typical)
Efficiency (Approx)	85%
Indicators	AC power and Back up
Protection:	Overload, Over Voltage, Short Circuit, Reverse Polarity
Approvals:	
Safety Standards No. N17018	AS/ANZ 60950:2000
C Tick No.N1408 (EMI, RFI)	AS/NZS2064 Group 1, Class A
Cooling	60 x 60mm Fan, load activated
Dimensions (mm)	233L x 115W x 70H
Weight	1.3Kg

Warranty Conditions: The product is warranted to be free from defects in materials and workmanship under normal use and service for a period of 24 months from the date of sale. This warranty covers defective parts and workmanship provided that the product is shipped prepaid to the seller within 24 months of purchase of goods. This warranty is limited to the repair or replacement (at the manufacturers' discretion) of parts and shipping prepaid to the original despatch destination. We regret that no liability can be accepted for consequential or special damages of any kind howsoever arising in connection with products supplied by the seller. This warranty is in lieu of all other warranties expressed or implied. No representative is authorised to assume for the seller any other liability in connection with the seller's products.