



Note: Before installation the user shall determine the suitability of the product to ensure correct application

1. Disconnect the battery supply.
2. Choose a mounting position. It is recommended to mount the unit inside the vehicle as the unit is not totally waterproof. Select a position with good ventilation where air can pass freely around the unit.

If unit is to be located externally, ensure it is:

- A. protected from water spray and other sources of contamination e.g. oil and grease.
- B. not located where external heat is produced e.g. exhaust stack (system) or next to batteries.

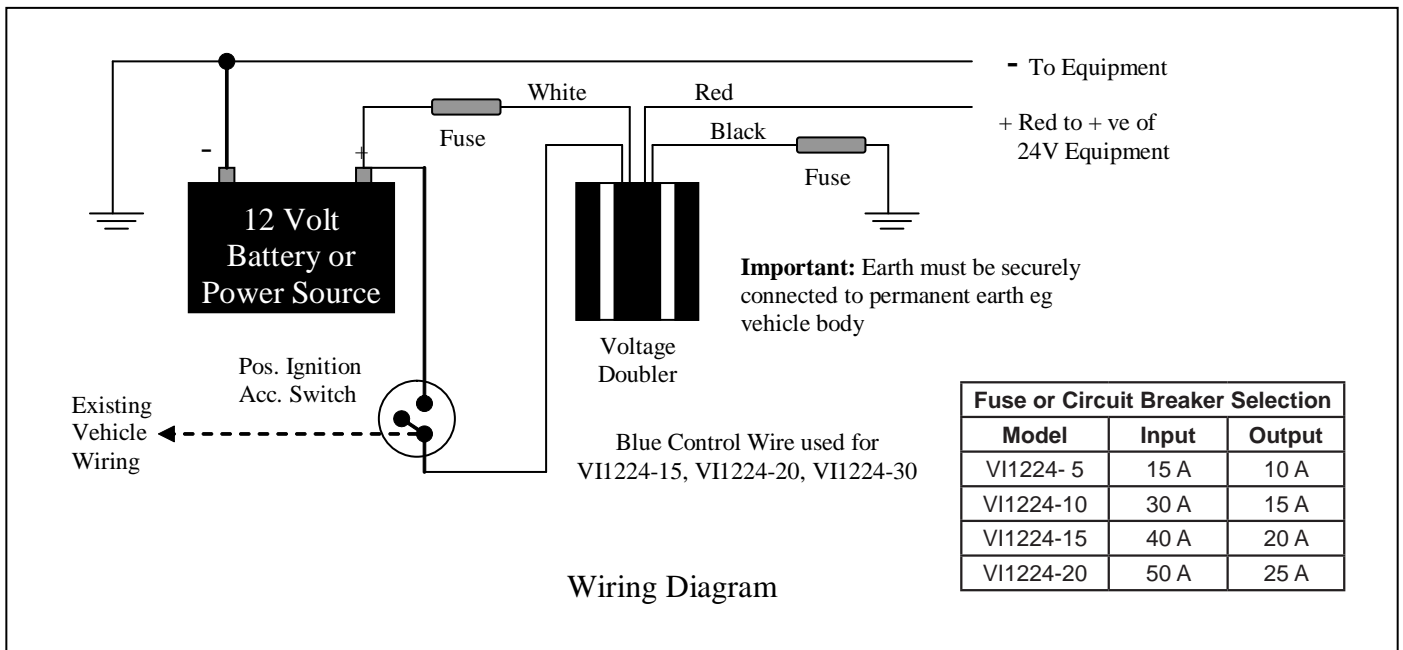

Warranty Conditions: The product is warranted to be free from defects in materials and workmanship under normal use and service for a period of 24 months from the date of sale. This warranty covers defective parts and workmanship provided that the product is shipped prepaid to the seller within 24 months of purchase of goods. This warranty is limited to the repair or replacement (at the manufacturers' discretion) of parts and shipping prepaid to the original despatch destination. We regret that no liability can be accepted for consequential or special damages of any kind howsoever arising in connection with products supplied by the seller. This warranty is in lieu of all other warranties expressed or implied. No representative is authorised to assume for the seller any other liability in connection with the seller's products.