

Note: Failure to follow all safety precautions and instructions may result in property damage, serious injury, or death to those you are trying to protect.

- Reverse alarms are intended for commercial vehicles. Proper installation of alarm should be carried out by a person who is familiar with electrical systems procedures and knowledge of Safety Warning Equipment.
- Care should always be taken when drilling holes into vehicle panels. Always ensure that the other “blind” side is clear.
- Location of the reverse alarm module is important as this should provide protection from damage from impact and adverse weather conditions as well as at the same time allow for unobstructed sound projection.

Maintenance

Inspections of the reverse alarm module should be carried out regularly to ensure that it is operating correctly.

Installation And Wiring

Select a mounting position at the rear of vehicle that will provide protection from impact, debris and adverse weather conditions. Generally reversing alarms should be installed approx. 1.2M above ground level with the speaker grill facing away from the rear of vehicle. When the module mounting position is selected, place the module in position and mark out where the 2 securing holes are to be drilled (check that all is clear behind panel prior to drilling). When holes are drilled, secure module to vehicle.

Module is now ready for wiring. *Refer to wiring diagram 1 below.*

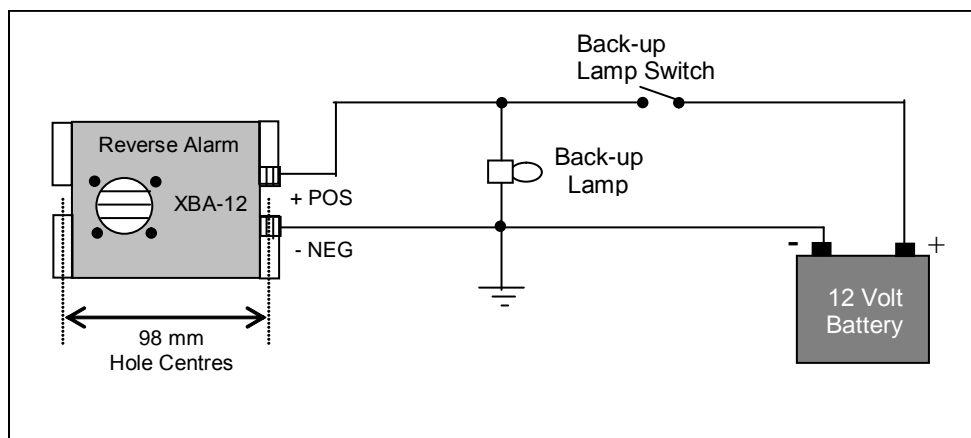

Diagram 1

Operation of Reverse Alarm Module

The operation is most simple, when reverse gear is engaged on the vehicle the reversing lamps illuminate and at the same time the reverse module begins to sound, This will continue to sound whilst ever reverse gear is engaged and the ignition (in most cases) is "on".

WARNING MESSAGE to the Driver:

Even though your vehicle has an audible reversing system, it is still your responsibility to ensure that the way is clear when reversing. Do not assume that a person or persons will move out of the way.

Specifications	
Electrical	
System Voltages suits	12 or 24 Volt DC
Voltage – Minimum	10.0 Volts DC
Maximum	36.0 Volts DC
Input current	40mA Average
Fuse at	2 Amp
Polarity	Positive or negative ground, polarity protected
Connection	Via 2 x 4.0mm Studs
Output	
Sound level	Input: 28 VDC - 105 dB(A) at 1.2M
Input: 12 VDC - 102 dB(A) at 1.2M	
Sound dispersion	Through 180°
Pulse Rate	60 pulses per minute
Frequency	1000Hz typical
Physical	
Electronics	Solid state
Sealing	Dipped in polymer coating to protect from moisture and dust
Housing	Black powder coated rigid extruded aluminium
Dimensions Overall mm (l x w x h)	110 x 63 x 34
Weight	133 gms
Mounting	Two (2) 8g S/T screws (not supplied), thru elongated slots located on side flanges. (98mm hole centres)
Operating Temperatures	-40°C to +75°C

Warranty Conditions: The product is warranted to be free from defects in materials and workmanship under normal use and service for a period of 24 months from the date of sale. This warranty covers defective parts and workmanship provided that the product is shipped prepaid to the seller within 24 months of purchase of goods. This warranty is limited to the repair or replacement (at the manufacturers' discretion) of parts and shipping prepaid to the original despatch destination. We regret that no liability can be accepted for consequential or special damages of any kind howsoever arising in connection with products supplied by the seller. This warranty is in lieu of all other warranties expressed or implied. No representative is authorised to assume for the seller any other liability in connection with the seller's products.