



The XLE 12 is a compact, rugged, all electronic brake controller and is easily installed with the connection of only four wires and the mounting bracket supplied. Easily adjust the brake pressure or emergency override with the slide bar control.

Note: for overriding, slide bar controls to the right and hold.
Designed for both single and dual axle trailers using negative earth (ground) systems only.

| | |
|--------------------------------|--------------------------|
| Maximum current | 5.5 amps (chopped pulse) |
| Number of Axles | 1 or 2 |
| Brake force indicator | Red LED |
| Brake circuit indicator | Green LED |
| Dimensions (mm) | 95L x 58W x 30H |
| Weight | 137gms |

Installation

1. Disconnect the vehicle's NEGATIVE battery terminal.
2. Determine a suitable mounting location.
 - a. The unit must be mounted securely to a solid surface.
 - b. The unit must be easily accessible to the driver.
 - c. The area behind the mounting location must be clear so nothing will be damaged when drilling.
3. Hold the mounting bracket in the selected position and mark the hole location through the holes in the bracket.
4. Using a suitable drill bit, drill holes in the marked locations.
5. Secure bracket in position with self tapping screws. Being careful not to strip the holes by over-tightening.
6. Mount the brake control unit in the bracket using the supplied screws.

Dual Colour LED – GREEN indicates the 12V supply and the trailer brake circuit are connected. RED indicates the brakes are energized. The brightness of red indicates the amount of braking force.

Set-up & Operation

1. To ensure unit is connected and operates correctly, initially set the slide control approximately half way, slowly roll the vehicle forward and stop. Move slide control to left (for less braking force) or right (for greater braking force) as required till braking is firm, but does not "jerk" or "lock up". Repeat process if necessary.
2. Test drive vehicle to ensure slide setting is appropriate, braking several times to ensure braking is smooth and firm, and remembering that the amount of braking required depends greatly on the trailer load and the speed of travel.

Initial connection

When trailer plug is connected to towing vehicle, the LED glows GREEN indicating connection has been made. Module operates towed vehicle brakes only.

Module Operation

The control module electronic circuit is activated by voltage being applied to the RED wire from the vehicle brake light switch.

Slide Bar Control Operation

Trailer braking force is adjusted by sliding the slide bar control located on the front of the unit from left to right and the LED Colour changes from GREEN through to RED as the braking force is increased.

Override Function

When the slide bar control is fully to the right and held in that position, the LED will glow RED and apply maximum braking force to the trailer brakes only. This position overrides the original braking force settings.

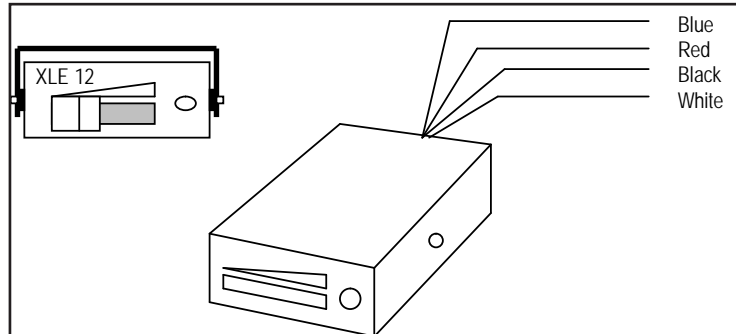

Wiring

The control module has four (4) coloured wires, black, red, blue and white. The black wire is the positive voltage power supply line. Using 4mm auto cable, connect a 15A self resetting circuit breaker to the positive side of the battery (preferred connection). The red brake wire powers up the electronic circuit of the module and must be connected to the cold side of the brake light switch. The blue brake wire must be connected directly to the trailer brake wire. The white ground wire is connected to grounded metal part of the dash or vehicle firewall.

Note: If the ignition circuit option is used, the brakes on trailer will not work until the ignition is switched “on”.

Important: A brake control unit that is not properly grounded may operate intermittently or not at all. Make sure all connections are soldered.

- Do not connect the Black “BATTERY” wire to the fuse panel or tie into any accessory wiring. Connecting to the existing wiring may damage the vehicles wiring and cause trailer brake failure.
- Do not reverse Black “BATTERY” wire and White “GROUND” connections. Even a momentary misconnection can damage the brake control unit.

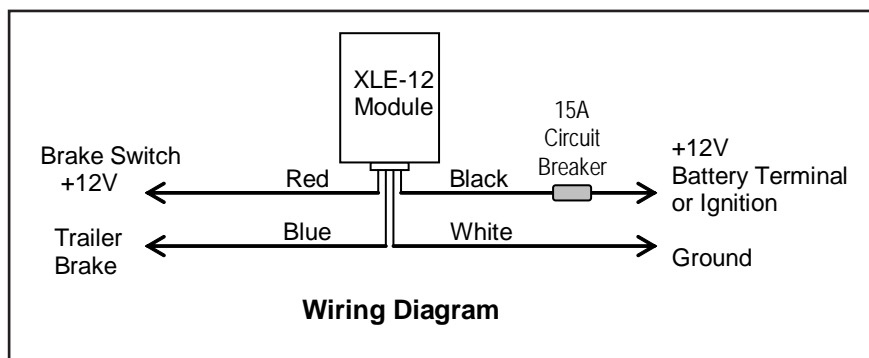

Warranty Conditions: The product is warranted to be free from defects in materials and workmanship under normal use and service for a period of 24 months from the date of sale. This warranty covers defective parts and workmanship provided that the product is shipped prepaid to the seller within 24 months of purchase of goods. This warranty is limited to the repair or replacement (at the manufacturers’ discretion) of parts and shipping prepaid to the original despatch destination. We regret that no liability can be accepted for consequential or special damages of any kind howsoever arising in connection with products supplied by the seller. This warranty is in lieu of all other warranties expressed or implied. No representative is authorised to assume for the seller any other liability in connection with the seller’s products.