

The unit is designed to protect the main vehicle battery from over discharge, by disconnecting the auxiliary accessories when the main battery voltage drops below 11.4 Volts. The accessories remain disconnected until such time as the battery voltage reaches normal charging voltage. The unit is designed to carry auxiliary loads of up to 10 Amps.

Installation

1. Disconnect the earth terminal from the battery.
2. Mount the unit with wiring facing downwards away from moisture and any source of external heat (e.g. exhaust systems).
3. Connect the Blue lead of the unit to the vehicle ignition circuit (positive).
4. Connect the Red lead of the unit to auxiliary equipment.
5. Connect the White lead of the unit to the auxiliary equipment earth (negative).
6. Connect the Black lead of the unit to the vehicle earth (negative).
7. Reconnect the earth terminal to the main vehicle battery and test unit.

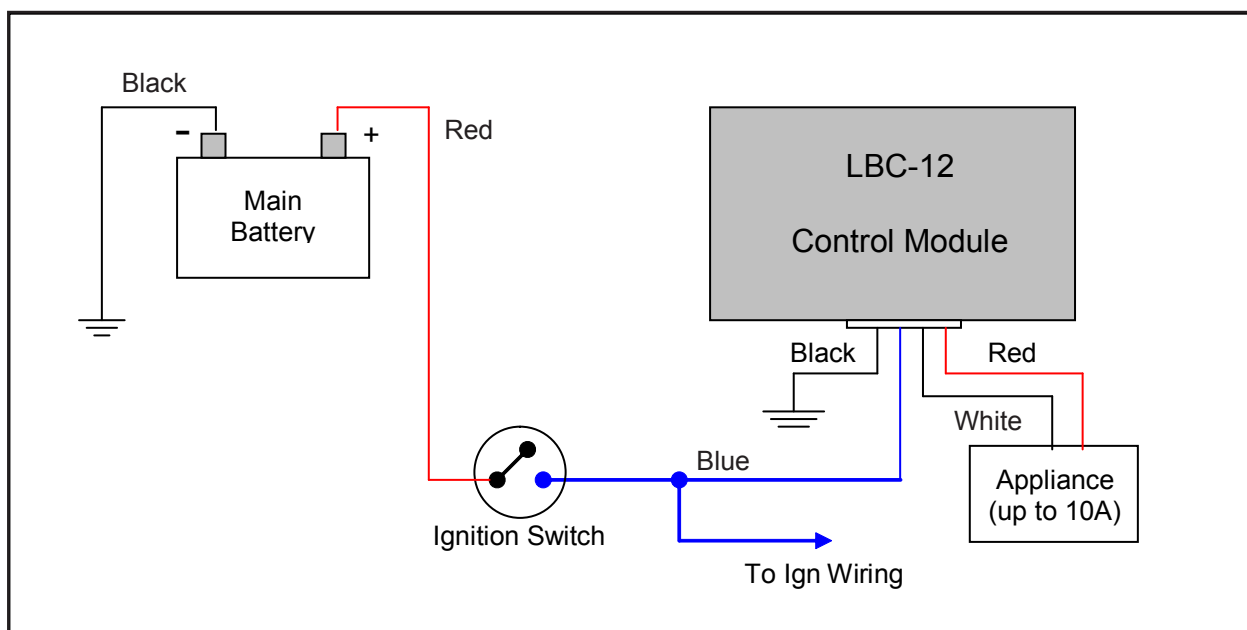

Warranty Conditions: Our products come with guarantees that cannot be excluded under the Australian Consumer Law. The customer is entitled to a replacement or refund for a major failure and compensation for any other reasonably foreseeable loss or damage. The customer is also entitled to have the products repaired or replaced if the products fail to be of acceptable quality and the failure does not amount to a major failure.

GSL Electronics (GSL) warrants that its products will, under normal use and service, be free of defects in material and workmanship for a period of two (2) years from the date of the original purchase by the customer as marked on the customer's original invoice. Please refer to our website for full warranty and return information which can be found at <http://www.gsl.com.au/faq.html>