

The unit is designed to protect the main vehicle battery from over discharge by providing a facility to give an audible and visual warning when battery voltage falls below 21V.

Installation

1. Disconnect the positive battery terminal.
2. Locate suitable areas to mount module, siren and lamp in vehicle dash area and secure.
3. Connect RED lead from unit to the positive terminal of the vehicle battery.
4. Connect WHITE lead from unit to siren and lamp.
5. Connect negative leads from siren and lamp to ground (earth).
6. Connect BLACK lead from unit to vehicle ground (earth).
7. Reconnect the main vehicle battery and test unit.

Note: Incandescent globe must be replaced with the same type and voltage. Not suitable for LED operation.

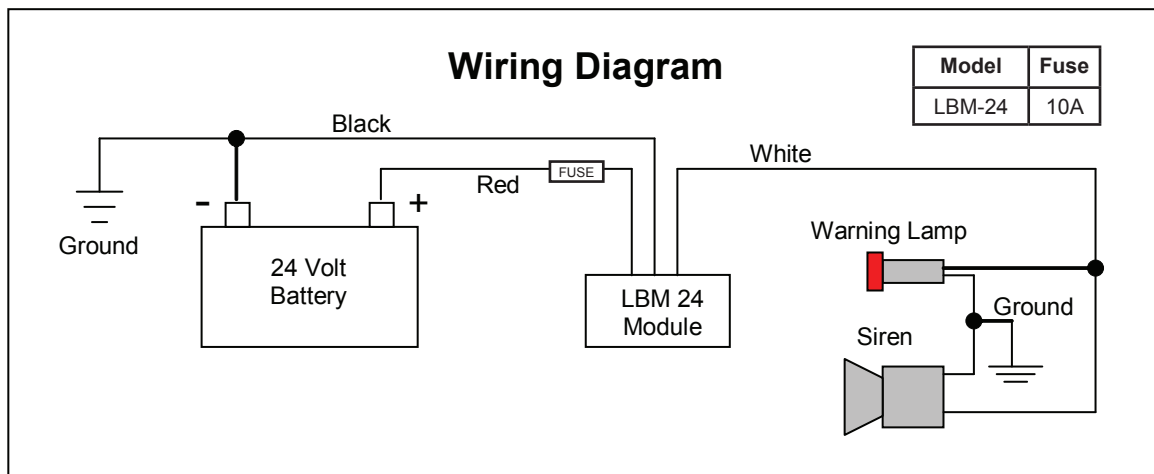

Warranty Conditions: Our products come with guarantees that cannot be excluded under the Australian Consumer Law. The customer is entitled to a replacement or refund for a major failure and compensation for any other reasonably foreseeable loss or damage. The customer is also entitled to have the products repaired or replaced if the products fail to be of acceptable quality and the failure does not amount to a major failure.

GSL Electronics (GSL) warrants that its products will, under normal use and service, be free of defects in material and workmanship for a period of two (2) years from the date of the original purchase by the customer as marked on the customer's original invoice. Please refer to our website for full warranty and return information which can be found at <http://www.gsl.com.au/faq.html>